

SuperSealer™

S H R I N K W R A P S Y S T E M



FREE
Maintenance Kit
See Warranty
Card



03080101S5MANPDF

OWNER'S GUIDE

SERIAL NUMBER:

PURCHASE DATE:

PURCHASED FROM:

DEALER PH NUMBER:

REVIEW ENCLOSED INSTRUCTIONS CAREFULLY
BEFORE USING THE SUPER SEALER™



185 Commerce Center, Greenville, SC 29615 | 864-297-8000 | Fax 864-297-7186 | www.InternationalPlastics.com

Safety Instructions

Before using your new SuperSealer, please take a few minutes to carefully read all the instructions. Pay close attention to safety guidelines and warnings included for your protection.

SAVE THESE INSTRUCTIONS FOR FUTURE REFERENCE.

WARNINGS for SuperSealer system (sealer & heatgun):

- Know your work environment. Make sure work area is clean and dry before using the sealer. This is an electrical appliance and can be a potential shock or fire hazard, especially if operated near refuse or in a wet environment.
 - Never operate the machine barefoot. Doing so greatly increases your risk of electrical shock.
 - The SuperSealer system should only be connected to a standard 115 volt 15 amp wall receptacle. No other form of wiring is safe or advisable. Unplug the system after use for additional safety precaution.
 - To reduce the risk of fire or electric shock, do not expose to rain or moisture. Store indoors.
 - Stay alert! Always pay attention to the work at hand and use common sense when operating this and all tools. Do not operate the sealer when you are tired or taking medication or drugs that may make you drowsy.
 - If the sealer or heatgun stops working during operation, fails to operate when turned on, or otherwise ceases to function properly, turn switch to the off position, disconnect from the power supply and call a qualified service technician.
 - Never attempt any repairs on the sealer or heatgun. A qualified service technician must do all repairs. The parts supplied in your maintenance parts kit are for maintenance of the machine to keep it in good operating condition and may be an exception to this rule.
 - Inspect power cords periodically and if damaged or defective, have repaired by a qualified service technician. Extension cords are not recommended, however if one is used it must be a U.L. listed three-wire extension cord with a three-prong grounding plug and a rated capacity of 1800 watts or greater (14 gauge or heavier for up to 25 ft. and 12 gauge if cord is longer). Inspect cord carefully before using and never use a cord that shows any sign of damage or defect.
 - Never yank the cord from an electrical outlet or use it to tie down the arm or for any other purpose other than that for which it was intended.
 - Guard against electric shock by preventing contact with grounded surfaces or other appliances.
 - Keep children and visitors away from the work area and the sealer and its accessories.
 - Keep work area well lighted.
 - Always store sealer in a safe place, out of the reach of children.
 - Never try to seal anything other than plastic shrink films intended for use on this sealer.
 - Never use the sealer after partial failure.
 - Maintain proper footing and balance at all times.
 - Do not wear loose-fitting clothing or jewelry. Wear non-skid footwear and a protective hair covering to contain long hair.
- Always wear eye protection and protective work gloves at all times.
 - When servicing, use only identical replacement parts.
 - Never use the sealer or heatgun near anything that is or could be considered combustible or flammable materials or gases. Always check your work area carefully; materials or gases that may ignite may not be readily apparent and could result in property damage and personal injury.
 - Never use the sealer or heatgun after recently pumping gasoline or using any other combustible gas or liquid; fumes or residue may still be on your skin or in your clothing.

WARNINGS specific to the sealer (In addition to system warnings):

- A live heating element is located on the underside of the arm under the Teflon tape. Use caution during operation. **DO NOT TOUCH THE ELEMENT.**
- Turn sealer off and disconnect (unplug) the sealer when not in use. Avoid unintentional starting. A sealer that is plugged in and left on could start and burn if the arm came down due to a broken spring or if something falls on the arm.
- If arm spring breaks, turn sealer off, disconnect from the power supply immediately and call a qualified service technician.
- Only use the AC outlet on side of machine with accessories intended for that purpose and rated to the capacity listed by the outlet. Specifically; an industrial heatgun.
- Only use fuse of capacity listed by the fuse holder.

SEALER CLEANING **INSTRUCTIONS:**

- Never use anything abrasive to clean the heating element. (i.e., steel wool, emery cloth or board, etc.) These can damage the wire & cause premature breakage.
- To clean the heating wire - first remove the pad from the channel under the arm. Then pull the arm down and allow the residue to burn off the arm. Wipe anything still clinging to the arm off with a piece of cardboard. After the wire has cooled & is visibly clean, cover with a new piece of 3 mil Teflon tape. NOTE: Teflon tape over the wire is only required when using PVC Shrink film or Polyethylene to prevent build-up on wire and excessive smoking. When using Polyolefin type films it is not required or suggested. The 10 mil Teflon tape on the sealing pad is always required for every application.
- To clean other exterior parts of the sealer, any non-flammable spray cleaner will suffice.
- Cleaning the internal sealer parts is not suggested or advised
- If Teflon tape appears to be burned, worn or damaged, replace with a new piece of tape.

WARNINGS specific to the heatgun (in addition to system warnings):

- For the first few uses of a new heatgun there may be some smoking due to manufacturing oils being burnt off inside the gun. The smoke should disappear in less than a minute.
- The nozzle will turn dark over time due to high heat. This is normal & does not effect the performance or shorten the life of the heatgun.
- The heatgun is supplied with a thermal cut-off switch located internally near the heating element to prevent overheating. This safety device is to prevent the heatgun from overheating and causing internal damage to its components. If your heatgun shuts off during use, or fails to operate when turned to low or high position, be sure to turn it off, unplug it from the outlet and call a qualified service technician for assistance. You may only need to wait for it to cool down (normally several minutes) and then turn it back on to use it again. However, never leave the heatgun unattended while it is on; especially with the switch turned on or after it has experienced partial failure.
- When you are finished using the heatgun, stand it on its convenient stand with the nozzle pointing up. This method is the best and safest way to allow it to cool after use and is the only way recommended by Traco Mfg. Inc. for cooling the heatgun between uses. Avoid laying the heatgun on its side. Do not point the heatgun in a downward position when cooling! This may cause residual heat to rise back into the heatgun and damage internal components and cause the heatgun to malfunction.
- Nozzle gets extremely hot. Do not touch the nozzle or place near combustibles.
- When storing the heatgun, allow it to cool completely (i.e., check the nozzle), and unplug it for storage.
- This is a heat gun, not a hair dryer. Heat gun intensity and extreme heat, even at the lowest settings, can burn hair and skin.
- Never obstruct the hot airflow by blocking or covering the air outlet at the nozzle or the intake at back end of the heatgun, and keep both ends free of dirt and debris.
- Never direct the hot airflow toward people or animals.
- Never touch the nozzle to any surface when running the gun or shortly after running it (while it is still hot).
- Turn the switch off and disconnect the heatgun when not in use. Avoid unintentional starting.
- Although there can be other uses for heatguns, only use this one for the purpose of shrinking plastic films (shrink wrap). Any other attempted use is at your own risk.
- Keep the heatgun moving constantly. Linger or pausing in one spot could burn or melt the shrink film and/or your product.

Heatgun cleaning instructions:

Use only a damp cloth to wipe the heat gun clean. Never use turpentine, paint thinner, gasoline, or similar substances to clean the gun.

SUPERSEALER™ SHRINK WRAP SYSTEM OPERATING INSTRUCTIONS

1. Plug power cord into 110 V AC 15A wall outlet.
2. Turn power on by depressing rocker switch. No warm-up time is required.
3. Plug the heat gun into AC outlet on left hand side of box.
4. Separate film and place around spreader bar. (If model is equipped with the optional perf roller, first load film between the perf wheel and plate, then around the spreader bar.)
5. Pull film to desired length on left hand side of sealing arm and sealing pad. Open film and insert package. Roll excess film back onto roll so that package is approximately even with edge of sealing pad.
6. Holding package in left hand bring the sealing arm down firmly onto the film and pad. With the arm in the down position, gently pull package away in a tearing motion from the pad until package is completely separated from pad. (When using the Deluxe Machine with timer, adjust dial to proper setting and bring the arm down until LED indicator turns off. Release arm and your cut and seal is now complete.) **IF THE CUTTING AND SEALING PROCESS TAKES LONGER THAN 3 TO 5 SECONDS, YOU ARE USING THE MACHINE INCORRECTLY AND YOU SHOULD CALL YOUR LOCAL REPRESENTATIVE FOR ASSISTANCE.** Turn package counter clockwise and repeat procedure to cut and seal the remaining edge of the film. (If model comes with the optional cutter blade located on the sealing arm, first position the blade to the middle of the film you are cutting. Next bring the sealing arm firmly down so the blade punctures the film, then slide the blade from side to side. With the arm still in the down position, gently pull package away from the pad.)
7. To shrink film around the product: adjust heat gun to desired temperature. Holding gun approximately 12" from product begin to shrink film around the seams first and then toward the middle in a circular motion until package has a glass-like appearance.

DO NOT HOLD GUN IN THE SAME POSITION FOR MORE THAN A FEW SECONDS. THIS WILL CAUSE THE FILM TO BURN RATHER THAN TO SHRINK.

WARNING: Heat gun should not be left on when air intake vents are blocked or for a prolonged period of time to prevent overheating! Make certain that switch is in the off position to ensure that both the blower and heating element are shut off, or heat damage may occur.



TROUBLE SHOOTING / RECOMMENDATIONS

Symptom: Centerfold shrink film will not separate or open.

Recommendation: If shrink film appears to be single sheet, place a strip of tape on top of the film and on the bottom and pull apart to initially separate.

Symptom: Film appears to smoke or is sticking to wire when seal is made.

Recommendation: This can mean one of several things:

1. With PP or PO film, wire must be kept clean by removing sealing pad and depressing arm until wire burns clean all film residue. No Teflon tape required on arm.
2. PVC film will smoke when seal is made. Teflon tape over the heating element will prevent the film from smoking and will occasionally need to be replaced. For Teflon tape or other parts, call the service number.

Symptom: Burning holes in shrink film with the heat gun.

Recommendation: If gun is set on high temperature and held in the same spot for more than a few seconds, the film will burn. Gun should be continually moving in a circular spiral motion from the outside edges of the package first, and to the middle of the package last.

Symptom: Arm is not properly cutting and sealing shrink film.

Recommendation:

1. On/Off switch may not be turned on.
2. Timer on Deluxe Model may not be set properly.
3. Arm may not be in complete contact with pad. (Gentle Pressure).
4. Excessive pressure applied to sealing arm.
5. Wire may need cleaning.

Symptom: Setting timer properly on the Deluxe Model.

Recommendation: Timer should be set to allow the minimal amount of time necessary to cut and seal the film. The setting will vary according to type of film in use. Setting timer too high will burn the film. PVC film will require a lower setting than most other films. Timer may need to be adjusted to lower setting as machine is used in a continuous or rapid manner.

Venting Your Shrink Package

The air inside the package expands as the film is heated. The quickest way to vent the film is to cut what amounts to an asterisk (*) into the closed end of the centerfold. The smaller your package, the more lines you should cut to make sure every package has at least one vent hole. This will prevent package from ballooning.

Cut Slits 1/16" deep

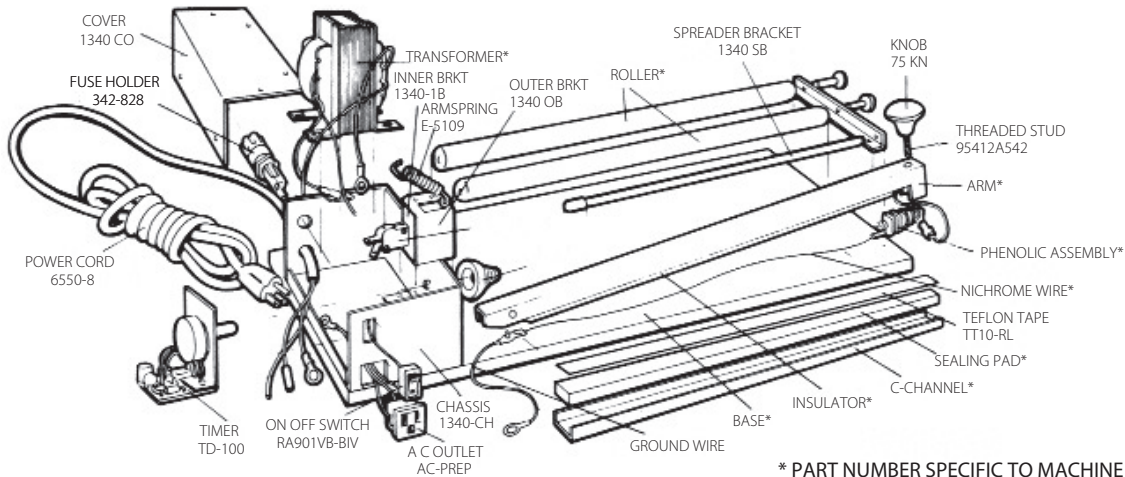
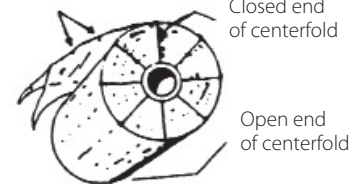

* PART NUMBER SPECIFIC TO MACHINE SIZE

SPECIFICATIONS

MODEL NUMBER	SS-13	SS-18	SS-24	SS-32	SS-40
Applications	Video Cassettes; Computer Software; CDs/Tapes Books/Magazines	Printing, Computer Software;Manuals; CDs/Tapes Hardwares	Printing; General packaging; Damaged Package Recovery	Art/Frame Gift Baskets Posters; Retail Packaging	Art/Frame Gift Baskets Posters; Retail Packaging
Length of Sealing Area	13"	18"	24"	32"	40"
Maximum Film Width	13"	18"	24"	32"	40"
Maximum Film Weight	100LBS	100LBS	100LBS	100LBS	100LBS
Film Core Diameter	1-7/8" & 3"	1-7/8" & 3"	1-7/8" & 3"	1-7/8" & 3"	1-7/8" & 3"
Power Supply (Primary)	110V AC*	110V AC*	110V AC*	110V AC*	110V AC*
Voltage (Secondary)(Deluxe)	14VAC	20VAC	30VAC	38VAC	38VAC
Amperage	3amps	5amps	5amps	8amps	8amps
Cycles	50/60hz. 1 phase	50/60hz. 1 phase	50/60hz. 1 phase	50/60hz. 1 phase	50/60hz. 1 phase

HEAT GUN 110 A/C - 60hz. - 1100 watts -- Temperature range: 50° F to 1100° F. Weight: 2LB.

* 220 VAC also available upon request.

LIMITED EQUIPMENT WARRANTY

Every Shrink Packaging System is thoroughly inspected and tested before leaving the factory warehouse. If any trouble should develop during warranty period, return the complete system prepaid to International Plastics. If after inspection, the unit is found to have defective workmanship or material, all due repairs will be made free-of-charge and the system will be returned freight prepaid.

This warranty does not apply when: repairs or attempted repairs have been made by non-factory personnel; repairs are required due to normal wear; the system has been abused or involved in an accident; the unit has been overloaded beyond its rated capacity; the system has been used with improper accessories; or the system has been used after partial failure.

Installation and operation of the equipment must comply with all applicable electrical and safety standards and is the sole responsibility of the purchaser.

NO OTHER WARRANTY, WRITTEN OR VERBAL IS AUTHORIZED

Parts not covered under the warranty due to normal wear: Teflon Tape; Sponge Rubber Sealing Pad; Nichrome Wires; Arm Springs.

Length of Warranty - 2 Years (1 year warranty on heat gun).

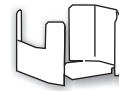

NEW! Heat Gun Stand



- Industrial-strength heat gun storage accessory
- One-piece, heat-resistant metal
- Built to last the life of your SuperSealer™



185 Commerce Center, Greenville, SC 29615
(864) 297-8000 • Fax (864) 297-7186 | www.InternationalPlastics.com

Cut & Mail to International Plastics:

Return Warranty Card for FREE Maintenance Kit!

Warranty Valid Only If Returned Within 10 Days of Purchase, one kit per customer.*

SERIAL NUMBER: _____

PURCHASE DATE: _____

*Upon receipt of completed warranty card, you will be sent a SuperSealer™ Maintenance Kit, free of charge.

**FREE
KIT**

Company Name: _____

Address: _____

City: _____ State: _____ Zip: _____

Your Type of Business or Business Category: _____

Products You Are Packaging: _____

What Influenced Your Purchase of the SuperSealer™?

- Distributor Magazine Ad Trade Show Other _____
 Traco Website PackExpo.com Product Literature